



HERZOG[®]
Braiding machines

CLEVER SOLUTIONS SINCE 1861

WIRE BRAIDING MACHINES **PZh 224** SERIES IN HORIZONTAL CONSTRUCTION

for the production of e.g. heavy protection shells

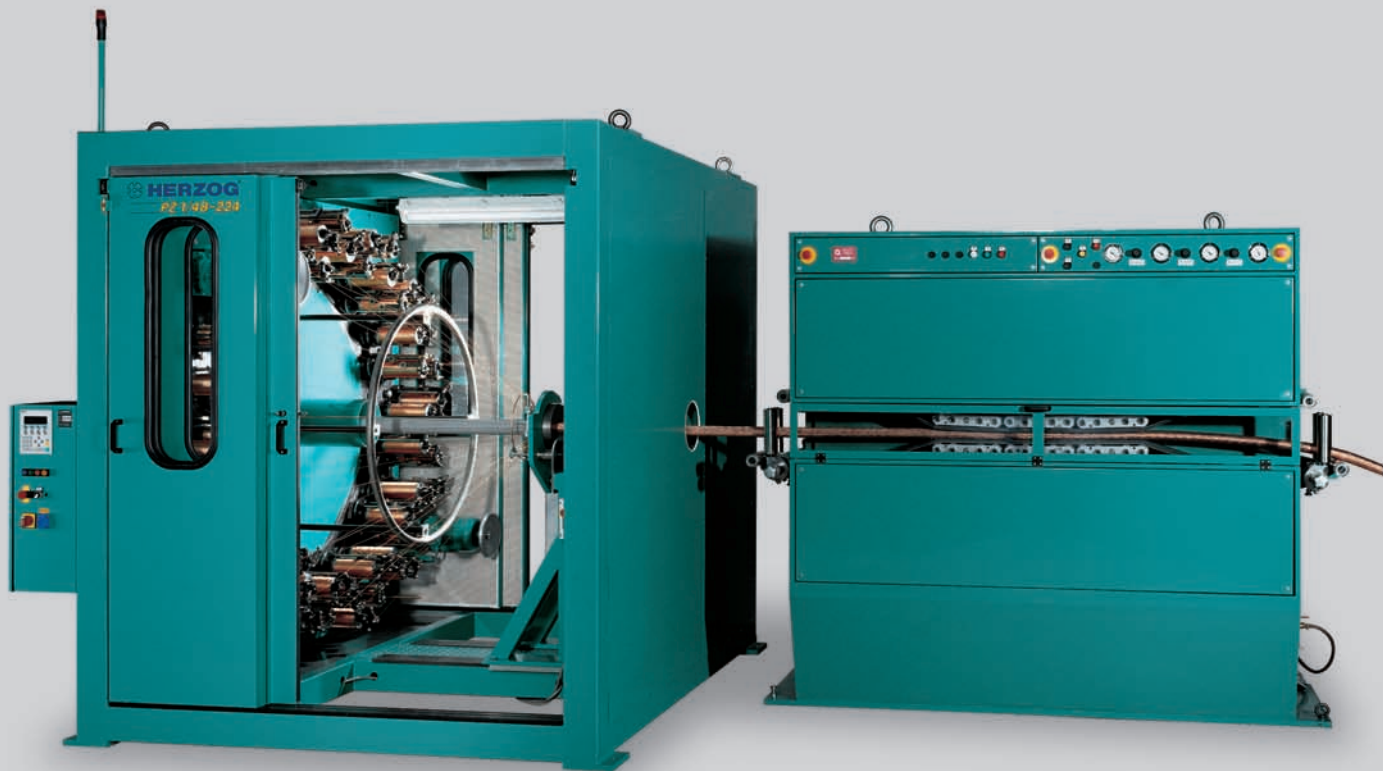

- ▶ Suitable to work steel-, aluminium- and copper-wire as well as textile yarns
- ▶ The optimum carrier for any kind of application
- ▶ Available with caterpillar take-off
- ▶ Most suitable for the covering of those cores that may not be deformed

August Herzog USA
109A Midsouth Drive
USA West End, NC 27376
Tel: +1 910 295 9763
Fax: +1 910 295 9764
e-mail: herzogusa@ac.net

August Herzog Maschinenfabrik GmbH & Co. KG
Postfach 20 01 52 · D-26045 Oldenburg
Am Alexanderhaus 160 · D-26127 Oldenburg
Telefon: +49 441/30 08-0 · Telefax: +49 441/30 08-100
<http://www.herzog-online.com>
e-mail: info@herzog-online.com

► TECHNICAL DATA



HERZOG[®]
Braiding machines

CLEVER SOLUTIONS SINCE 1861

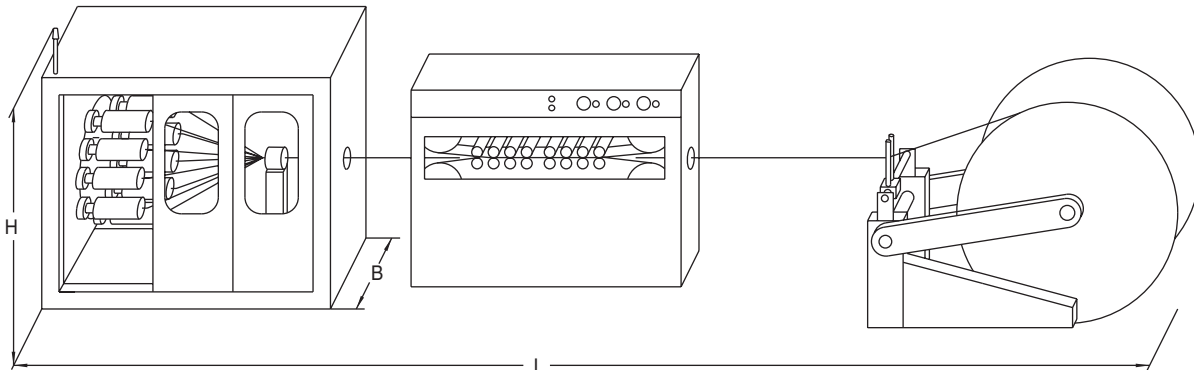

► Machine type	PZh 1/16-224	PZh 1/24-224	PZh 1/32-224	PZh 1/36-224	PZh 1/48-224
Number of carriers	16	24	32	36	48
Pitch size in mm	224	224	224	224	224
Length in mm (L)	1600	1850	2100	2250	2600
Width in mm (B)	1350	1650	1950	2100	2500
Height in mm (H)	2200	2350	2500	2600	3000
Motor power in kw	1,1	1,5	2,2	2,2	3,0
Speed (horngear r.p.m.)	110	110	110	110	110
Center tube, diameter in mm	200	510	800	900	1230
Carrier type for wire	AFD 224	AFD 224	AFD 224	AFD 224	AFD 224
Bobbin size in mm	105 x 200	105 x 200	105 x 200	105 x 200	105 x 200
Bobbin volume in ccm	1505	1505	1505	1505	1505

► Options					
Carrier type for textile yarns	AFZP 224	AFZP 224	AFZP 224	AFZP 224	AFZP 224
Bobbin size in mm	124 x 380	124 x 380	124 x 380	124 x 380	124 x 380
Bobbin volume in ccm	4223	4223	4223	4223	4223
Multi-roller take-off	<input type="radio"/>	<input type="radio"/>	<input type="radio"/>	<input type="radio"/>	<input type="radio"/>
Caterpillar take-off	<input type="radio"/>	<input type="radio"/>	<input type="radio"/>	<input type="radio"/>	<input type="radio"/>
Electronic lay length control	<input checked="" type="radio"/>	<input checked="" type="radio"/>	<input checked="" type="radio"/>	<input checked="" type="radio"/>	<input checked="" type="radio"/>
Take-up onto drums	separate	separate	separate	separate	separate
- with UHING device	<input checked="" type="radio"/>	<input checked="" type="radio"/>	<input checked="" type="radio"/>	<input checked="" type="radio"/>	<input checked="" type="radio"/>
Braiding ring	<input checked="" type="radio"/>	<input checked="" type="radio"/>	<input checked="" type="radio"/>	<input checked="" type="radio"/>	<input checked="" type="radio"/>
Movable braiding die	<input checked="" type="radio"/>	<input checked="" type="radio"/>	<input checked="" type="radio"/>	<input checked="" type="radio"/>	<input checked="" type="radio"/>
Yarn break control	<input checked="" type="radio"/>	<input checked="" type="radio"/>	<input checked="" type="radio"/>	<input checked="" type="radio"/>	<input checked="" type="radio"/>
Metercounter/timer meter	<input checked="" type="radio"/>	<input checked="" type="radio"/>	<input checked="" type="radio"/>	<input checked="" type="radio"/>	<input checked="" type="radio"/>
Housing with lighting, safety doors and windows	<input checked="" type="radio"/>	<input checked="" type="radio"/>	<input checked="" type="radio"/>	<input checked="" type="radio"/>	<input checked="" type="radio"/>
Infinitely variable speed control	<input type="radio"/>	<input type="radio"/>	<input type="radio"/>	<input type="radio"/>	<input type="radio"/>
Rolling unit	<input type="radio"/>	<input type="radio"/>	<input type="radio"/>	<input type="radio"/>	<input type="radio"/>
Central lubrication	<input checked="" type="radio"/>	<input checked="" type="radio"/>	<input checked="" type="radio"/>	<input checked="" type="radio"/>	<input checked="" type="radio"/>

Also available with 64, 72 or 96 carriers.

● Standard ○ Option Subject to technical changes due to further development.