



HERZOG[®]
Braiding machines

CLEVER SOLUTIONS SINCE 1861

SOUTACHE BRAIDING MACHINES

ST 80 – ST 210 SERIES

pitch sizes from 80 – 210 mm



- ▶ simple to operate
- ▶ various carrier types
- ▶ low maintenance required
- ▶ reliable in continuous operation
- ▶ high bobbin volume

August Herzog USA
109A Midsouth Drive
USA West End, NC 27376
Tel: +1 910 295 9763
Fax: +1 910 295 9764
e-mail: herzogusa@ac.net

August Herzog Maschinenfabrik GmbH & Co. KG
Postfach 20 01 52 · D-26045 Oldenburg
Am Alexanderhaus 160 · D-26127 Oldenburg
Telefon: +49 441/30 08-0 · Telefax: +49 441/30 08-100
<http://www.herzog-online.com>
e-mail: info@herzog-online.com

► TECHNICAL DATA



HERZOG®
Braiding machines

CLEVER SOLUTIONS SINCE 1861

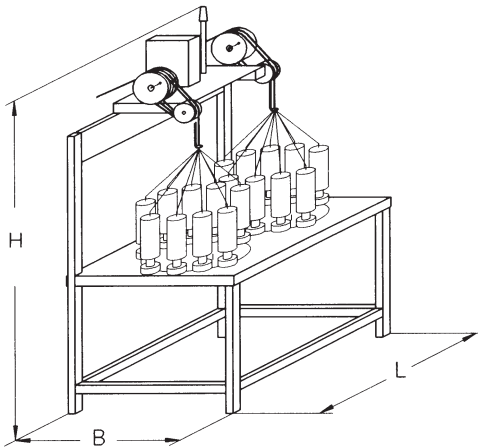

| ► Machine type* | ST 6/3-80 | ST 4/5-100 | ST 4/7-140 | ST 4/3-140 | ST 4/9-180 | ST 4/7-180 | ST 1/3-210 |
|-----------------------|-------------------------|------------|------------|------------|------------|------------|------------|
| Number of heads | 6 | 4 | 4 | 4 | 4 | 4 | 1 |
| Carriers per head | 3 | 5 | 7 | 3 | 9 | 7 | 3 |
| Pitch size in mm | 80 | 100 | 140 | 145 | 175 | 175 | 210 |
| Length in mm (L) | 735 | 735 | 905 | 1075 | 1075 | 1075 | 610 |
| Width in mm (B) | 440 | 440 | 465 | 535 | 535 | 535 | 780 |
| Height in mm (H) | 1600 | 1600 | 1600 | 1730 | 1730 | 1730 | 1730 |
| Weight in kgs | 170 | 170 | 180 | 270 | 260 | 280 | 300 |
| Motor power in kw | 0,25 | 0,25 | 0,25 | 0,37 | 0,37 | 0,37 | 0,37 |
| Speed (horn gear rpm) | 250 | 220 | 140 | 235 | 110 | 110 | 90 |
| Carrier type | IFDA-Z-80 IFDA-Z-100 | IFDA-Z-80 | IFDA-Z-80 | AFD 140 | IFDA-Z-80 | IFDA-Z-100 | AFD 266 |
| Bobbin size in mm | 42 x 130 55 x 170 | 42 x 130 | 42 x 130 | 74 x 250 | 42 x 130 | 55 x 170 | 135 x 300 |
| Bobbin volume in ccm | 148 346 | 148 | 148 | 962 | 148 | 346 | 4005 |
| 3-roller take-off | ● | ● | ● | ● | ● | ● | ● |

| ► Options | | | | | | | |
|--------------------------------|----------|----------|----------|----------|----------|----------|-----------|
| Take-off for braiding into can | ● | ● | ● | ● | ● | ● | ● |
| Warp thread control | ○ | ○ | ○ | ○ | ○ | ○ | ○ |
| Guiding tubes | ○ | ○ | ○ | ○ | ○ | ○ | ○ |
| Bored horn gear pillars | ● | ● | ● | ● | ● | ● | ● |
| Metercounter/time meter | ○ | ○ | ○ | ○ | ○ | ○ | ○ |
| Take-up onto drums | ○ | ○ | ○ | ○ | ○ | ○ | ○ |
| Drum size in mm | 300 x 75 | 300 x 75 | 300 x 75 | 300 x 75 | 300 x 75 | 300 x 75 | 370 x 200 |
| Open guides at the carrier | ○ | ○ | ○ | ○ | ○ | ○ | ● |

* Other machine types available upon request.

● Standard ○ Option

Subject to technical changes due to further development.